



Defender™ 3000

Bench Scales



Designed with affordability in mind, but with no compromise on quality!

The OHAUS Defender™ 3000 Series economy line of bench scales is ideal for general weighing and simple counting applications in production, packaging, warehouse, inventory, shipping and receiving areas. The Defender 3000 Series feature a simple, yet rugged, tubular-frame base design and indicators with tactile keys, backlit LCD display, built-in rechargeable battery operation and flexible mounting capabilities. The Defender 3000 Series is the solution to your weighing applications that require dependability within an affordable budget.

Standard Features Include:

- Currently, three capacity models: 60lb/30kg, 150lb/60kg and 300lb/150kg
- Maximum Resolution 1:6000-7500d
- 304 stainless steel pan with painted carbon steel frame and aluminum IP67 load cell
- Adjustable non-slip rubber leveling feet with externally visible level indicator
- T31P indicator features a high-impact durable ABS housing with reversible face for either wall, column or table-top mounting
- Multiple weighing units: lb, oz, lb:oz, kg, g
- Parts counting mode with selectable sample sizes, last sample size and Average Piece Weight data
- 1-in/25mm high LCD weight display with high-contrast backlight
- Built-in RS232 for printing and data connection
- AC adapter and internal rechargeable lead acid battery

Defender™ 3000 Bench Scales

Specifications

Models	D31P30BR	D31P60BR	D31P60BL	D31P150BL
Capacity x Readability (d)	60 lb x 0.01 lb 960 oz x 0.2 oz 60 lb x 0.2 oz (lb:oz) 30 kg x 0.005 kg 30000 g x 5 g	150 lb x 0.02 lb 2400 oz x 0.5 oz 160 lb x 0.5 oz (lb:oz) 60 kg x 0.01 kg 60000 g x 10 g	150 lb x 0.02 lb 2400 oz x 0.5 oz 160 lb x 0.5 oz (lb:oz) 60 kg x 0.01 kg 60000 g x 10 g	300 lb x 0.05 lb 4800 oz x 1 oz 300 lb x 1 oz (lb:oz) 150 kg x 0.02 kg 150000 g x 20 g
Maximum Displayed Resolution	1:6000	1:6000	1:6000	1:7500
Load Cell Protection	IP67			
Base Construction	304 stainless steel pan with painted carbon steel frame, non-slip rubber leveling feet			
Platform Dimensions (W x D x min H)	12 x 14 x 4.8 in / 305 x 355 x 123 mm		16.5 x 21.6 x 5.4 in / 420 x 550 x 136 mm	
Column	13.8 in / 350 mm fixed height, tubular painted steel		27.6 in / 700 mm fixed height, tubular painted steel	
Leveling Component	Externally visible level bubble and adjustable leveling feet with locking nuts			
Safe Overload Capacity	125% of rated capacity			
Indicator Construction	ABS plastic housing			
Weighing Units	lb, oz, lb:oz, kg, g			
Functions	Weighing, Parts Counting			
Weight Display	6-digit, 7-segment backlit LCD, 1 inch / 25 mm high digits			
Keyboard	4 function mechanical keys, raised, tactile			
Stabilization Time	Within 2 seconds			
Auto-zero Tracking	Off, 0.5, 1 or 3 divisions			
Key Zeroing Range	2% or 100% of capacity			
Span Calibration	5 lb/kg to 100% of capacity, user selectable			
Power	AC adapter with 100-hour internal rechargeable lead acid battery included			
Interface	Bidirectional RS232C			
Operating Temperature Range	14°F to 104°F / -10°C to 40°C, Maximum relative humidity 80 % for temperatures up to 31°C / 88°F, decreasing linearly to 50 % relative humidity at 40°C / 104°F, non condensing			
Net Weight	26 lb / 11.8 kg		41 lb / 18.6 kg	
Shipping Weight	36 lb / 16.4 kg		54 lb / 24.5 kg	
Shipping Dimensions	25.3 x 19.6 x 8.5 in / 642 x 497 x 212 mm		33.7 x 22.2 x 8.9 in / 857 x 564 x 225 mm	

Features

ABS plastic housing with internal rib reinforcements, reversible front/rear cover, backlit LCD weight display, tactile mechanical keys, built-in bidirectional RS232C with manual/continuous/interval printing, hardware configuration lockout switch, internal lead-acid rechargeable battery and AC adapter. Software included for parts counting mode with selectable sample sizes, selectable span calibration points, averaging level, auto-zero tracking, battery saving auto-off, Geo Code geographical gravity calibration adjustment and software menu lockouts. Stainless steel pan with painted carbon steel tubular frame, non-slip rubber leveling feet with locking nuts, externally visible level bubble, aluminum IP67 load cell, down-stops for overload protection, hollow tubular painted steel columns.

Accessories

T31P Indicator wall mount bracket kit (painted carbon steel, includes adjustment knobs), part number 80251747

Approvals

- Safety and EMC: EN60950, EN61326, FCC, CE, cUL_{US}
- Quality: OHAUS quality management system registered to ISO 9001:2000

Outline Dimensions (inches)

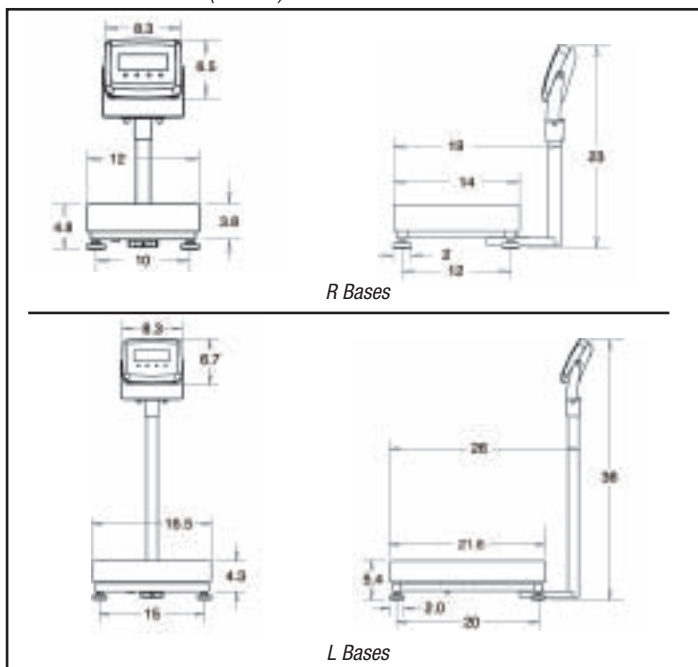

Ohaus Corporation

* 19A Chapin Road
P.O. Box 2033
Pine Brook, NJ 07058 USA

Tel: 800.672.7722
973.377.9000

Fax: 973.944.7177

www.ohaus.com

With offices throughout Europe,
Asia, and Latin America

* ISO 9001:2000

Registered Quality Management System

80774284 © Copyright Ohaus Corporation

